

Article Info

Received: 11 Jan 2020 | Revised Submission: 29 May 2020 | Accepted: 30 Jul 2020 | Available Online: 15 Sept 2020

IOT Based Wearing Visual Assistance System Based on Binocular Sensors

Vijay Bhandari*, Kalpana Rai** and Ritu Shrivastava***

ABSTRACT

Usually the concert of visual photoelectric is exaggerated from a fusion of compound factors in resultant in a huge numeral of sound and alteration. In this article, we will do efficient iot-wva system based on bc sensors for vis person cleverly force image eminence valuation to go for the captured imagery during v-sensors, which can make sure the participation quality which improves the scenes for the ending of classify the system. Here we performed simulation and experiment show that the proposed system can solve the predicament in effect. There is a way in which we will add computation, arithmetical consequences also demonstration the wearable vision (wv) organization prepared vi grouping creates additional contented in diagrams and finally it is desirable state.

Keywords: Binocular apparition sensors; Wearable supporter system; Stereo representation quality assessment; CNN.

1.0 Introduction

There is observation in this era before two decade any changes in the go forward to CV will do efficient iot-wva system[1-5] based on bc sensors for vis person. Before one decade, a multiplicity of checkup tackle has been residential to [4]–[6] overcome this problems. Here it will do efficient iot-wva system based on bc sensors for vis person. Although, the techniques of real-time demonstrate the visual detection method based on wearable devices will increase the life experience, then we can say here bridging the gap between vi and general people's sense of practice [7-19]. Now we add the elder populace will solve the similarity during finding the difficulty in their life, and how to aid their live sustaining is also a subject of praiseworthy in search [10-20]. It will do efficient iot-wva system based on bc sensors for vis person. Many investigate efforts have been complete on design of chart mutilation auxiliary techniques [11-20]. As in figure [10-20] propose a wear-able organization for sightless or VIU people's is working on based of big

data and IQA. In the future system, these following point giving contribute to this article can be give to increase accuracy in the performance of WVA system[30-39] for people's health. It will do efficient iot-wva system based on bc sensors for vis person. The selection of bcv sensors will facilitate the whole organization [30-40]. Here we will do efficient iot-wva system based on bc sensors for vis person because the majority[41-43] of the PCSC stastics data through MC–BC camera, the data which is not accurate and consistent with the basic characteristics and features of the HEVS[6-10]. We will prepare an efficient iot-wva system based on bc sensors for vis person we can see in fig.1.

2.0 Proposed Work

The main goal of this article to propose a develop an efficient iot-wva system based on bc sensors for vis person .WVAS system for B&V impaired users based on BD and BS. We are taking into consideration the preceding deliberations in associated contemplated work. There are three

*Corresponding author; Department of Computer Science & Engineering, Sagar Institute of Research Technology & Science, Rajiv Gandhi Technical University, Bhopal, Madhya Pradesh, India (E-mail: vijaysirt@gmail.com)

**Department of Computer Science & Engineering, Sagar Institute of Research Technology & Science, Rajiv Gandhi Technical University, Bhopal, Madhya Pradesh, India (E-mail: kalpana.raii23@gmail.com)

***Department of Computer Science & Engineering, Sagar Institute of Research Technology & Science, Rajiv Gandhi Technical University, Bhopal, Madhya Pradesh, India (E-mail: ritushrivastava08@gmail.com)

aspects are given related to the motivation. In the first subsection, BC- lar sensors will be design compared with MC sensor. Particularly, bv systems theory in HVS will be introduced. In the second subsection, the research of article in stereo images quality study and survey will be reviewed, and also it can support the choice of taking photos, metaphors from wvs.

Figure 1: Human Binocular Vision System

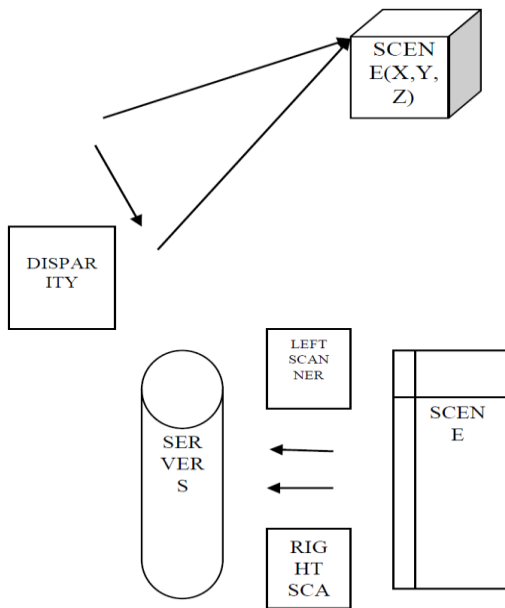

The last subsection focuses on OB discovery. We will do efficient iot-wva system based on bc sensors for vis person here we can give single instance of the preceding BC design. We are calculating the disparity of calculation and computing is shown in Equ. 1.

$$C = E_l / E_l + E_r + 1 \quad \dots (1)$$

$$Disparity = f_x - f_z \quad \dots (2)$$

Due to symmetrically unclear UP pairs, left imagery of stereo pairs are only VISIBLE. (i) a perfect picture. (ii) DMS = 2.8898. (iii) DMS = 110.8989. (iv) DS = 22.6898 (v) DMS = 36.8685. (vi) DM = 45.898. The higher DMOS, the MQ

An efficient iot-wva system based on bc sensors for vis person It is DL – Learning method is a very EM technique. In this article to find a potential object that needs and improves to be recognized, the coldness from the article ,we found EV of a control system is a rational technique. However, the limits of this technique are also very understandable as we can see in figure 3. Furthermore we will do efficient iot-wva system based on bc sensors for vis person see

binocular vision formula as we can see For bvs, the log tabor filter $t_{t,s,o}(\omega, \theta)$ is to be used for the investigation of these bvs systems, as shown in Eq. 3.

Figure 2: Stereo Pairs in Dissimilar IQ Images and the Matching dmoc (DMS) in Subsist 2-D Phase First db



Figure 3: TDL Model CNN Model and Network

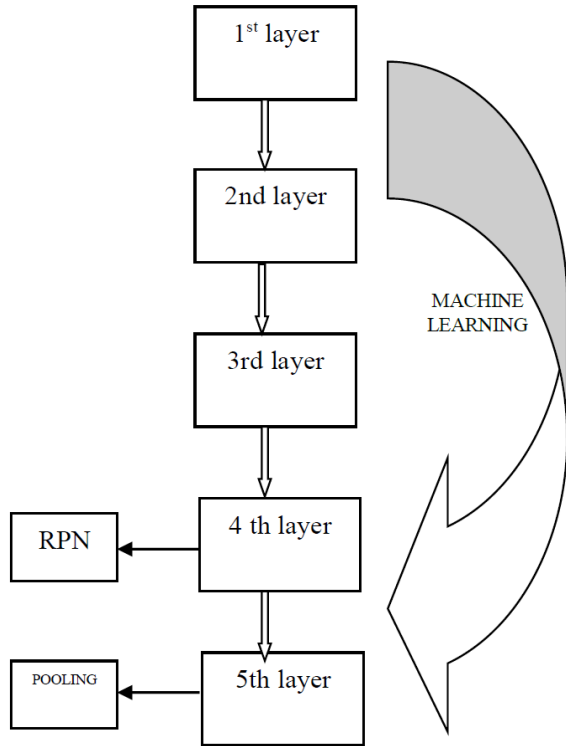

An efficient iot-wva system based on bc sensors for vis person ωo are having usually used to analyse the filter FE, ω and ωs giving acknowledge of the normalized rff and the CF. In this article , we can work out the indication of c state in the dimension of S, in the way of the local energy information:

$$Eo(c) = Fo(c)2 + Ho(X)^2 \quad \dots(4)$$

where

$$Fo(c) = \sum \eta s,o(c), Ho(c) = \sum \zeta s,o(c) \quad \dots(5)$$

Efficient iot-wva system based on bc sensors for vis person Based on this article contemplated work , the real-time representation prepared composed by the bcs to form sources inputs of the stereo images. In addition, the cycles per second which is called frequency in terms of IA will be prohibited at least 10 f/s.

$$Q = \omega 1 Q_{stereo} + \omega 2 Q_{n \text{ stereo}} \quad \dots(6)$$

For stereo part, we make a decision features extract from difference map, it can be distinct as Q_{stereo} . As we are proposing non-stereo images, we only contract with it as a only 2D picture, which can be defined as $Q_{nonstereo}$. Then the assessment consequences can be obtain through dissimilar parts. Based on the new test, it can be distinct that $\omega 1 = .23878$ and $\omega 2 = 0.789874585$ in Equ. 6

For illustration , we are giving a a potential detecting an object with $4^5 \times 4^5$ in degree can be transformed as only 3 by 3 matrix in resolution from side to side cc in Res-Net network. So we find the imprecise local when opposite object detection. Based on this consideration,

$$y = F(x, W_i) + W_s x \quad \dots(7)$$

Figure 4: FL of Endeavored Ways of System

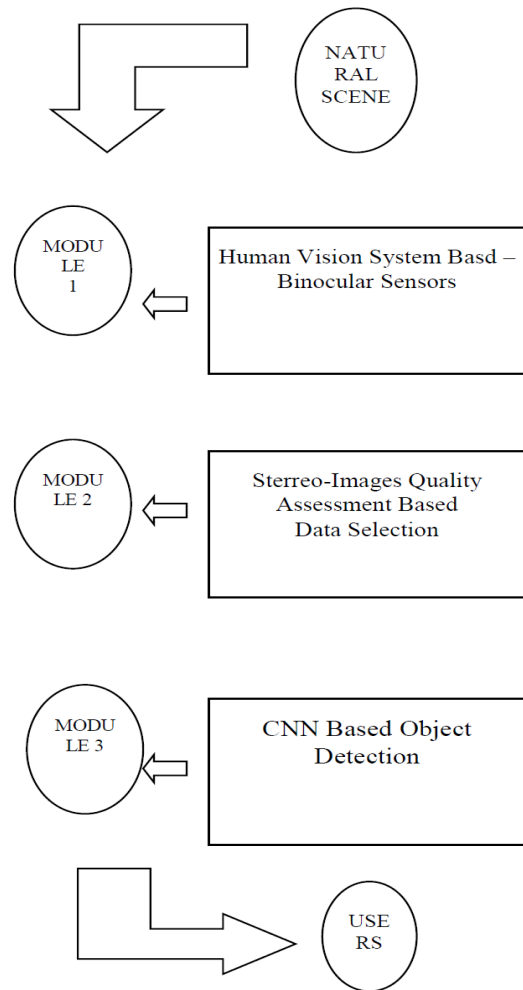

3.0 Test Protocol and Experimental Results

As stated by the above psychoanalysis, the bsv part will give the profundity and legitimacy of the "stereoscopic vision -sv" stereo image, we can define the rest of the part where it will determine[15-25] the indispensable class of the likeness [33-39]. In order to fully decay the image, we use the ht transformation to notice the boundary in sequence where the most successful SI statistic data. In oldest

time, image processing, HT where hough transform is an effective feature retrieval method, which can be used for obsession determining the discovery based in this article.

In this section, the trial standard and presentation procedure, which can spot the correctness for the intended wearable scheme.

Figure 5: MIAD

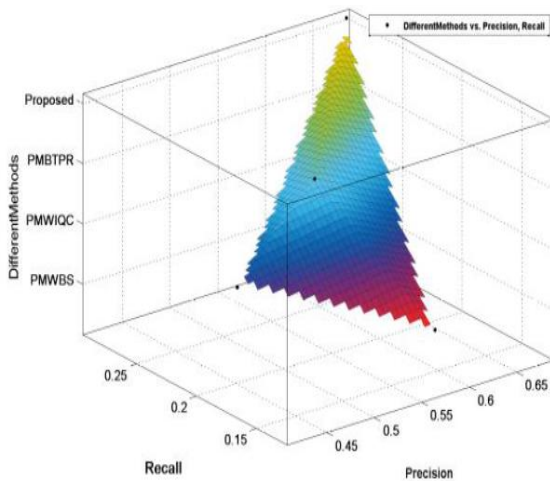
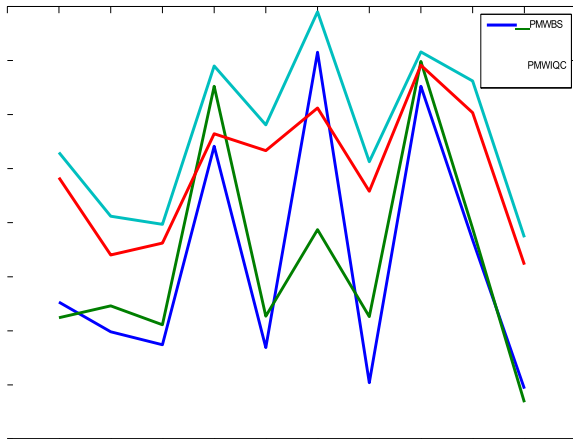

Figure 6: The Comparison of the Four Different System in Simulation Environment



Efficient iot-wva system based on bc sensors for vis person For each estimate, we conduct 20 experiments to getting the continuous function value to offset the effective in unintentional factors. Efficient iot-wva system based on bc sensors for vis person via figure 6 and tables 1 and 2. Which is better than preceding algorithm. iot-wva system based on bc sensors for vis person is having good results have shown in table 2.

Table 1: Efficient iot-wva System Based on bc Sensors

PMWBS	0.56	0.212	0.568	0.023	0.852	0.293	0.527
PMWQC	0.111	0.446	.321	0.022	0.898	0.268	0.533
PMBTPR	0.239	0.287	0.258	0.658	0.891	0.522	0.727
Proposed	0.235	0.214	0.236	0.666	0.987	0.873	0.866

Table 2: Continuous Function Value

	Persons	Trees	Monuments
PMWBS	0.115	0.121	0.127
PMWQC	0.126	0.113	0.132
PMBTPR	0.141	0.192	0.174
Proposed	0.173	0.221	0.197

Figure 7: The Evaluation of Dissimilar (EOD) Methods in Collected Stereo Image Databases SID

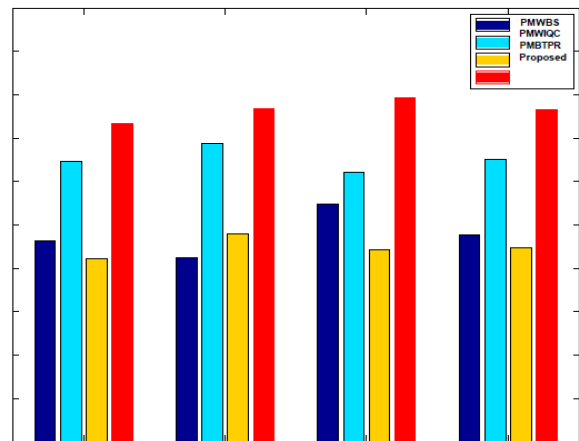

4.0 Conclusions

Finally we have done efficient iot-wva system based on bc sensors for vis person. It is captured descriptions are directly giving on cloud for further computation work. We emphasize on this process it can complete discovery and routine inform for all the received imagery. Convolution neural network in big data is used in this article. We found image analysis and we performed will do efficient iot-wva system based on bc sensors for vis person.

References

[1] B Montrucchio, C Celozzi, P Cerutti. Thresholds of vision of the human visual system: Visual adaptation for monocular and binocular vision. IEEE Transactions on Human-Machine Systems, 45(6), 2015, 739–749.

- [2] M Georgeson, S Wallis, T Meese, D Baker. Contrast and lustre: a model that accounts for eleven different forms of contrast discrimination in binocular vision. *Vision Research*, 129, 2016, 98–118.
- [3] D Saint-Amour, V Walsh, J Guillemot, M Lassonde, F Lepore. Role of primary visual cortex in the binocular integration of plaid motion perception. *European Journal of Neuroscience*, 21(4), 2015, 1107–1115.
- [4] W Hou, X Gao, D Tao, X Li. Blind image quality assessment via deep learning. *IEEE Transactions on Neural Networks and Learning Systems*, 26(6), 2015, 1275, 2015.
- [5] Y Liu, J Yang, Q Meng, Z Lv, Z Song, Z Gao. Stereoscopic image quality assessment method based on binocular combination saliency model. *Signal Processing*, 125(C), 2016, 237–248.
- [6] YH Lin, JL Wu. Quality assessment of stereoscopic 3d image compression by binocular integration behaviors. *IEEE Transactions on Image Processing*, 23(4)s, 2014, 1527–1542.
- [7] F Shao, K Li, G Jiang, M Yu, C Yu. Monocular-binocular feature fidelity induced index for stereoscopic image quality assessment. *Applied Optics*, 54(33), 2015, 9671–9680, 2015.
- [8] F Shao, W Lin, S Wang, G Jiang, M Yu. Blind image quality assessment for stereoscopic images using binocular guided quality lookup and visual codebook. *IEEE Transactions on Broadcasting*, 61(2), 2015, 154–165, 2015.
- [9] W Zhang, L Ma, J Guan, R Huang. Learning structure of stereoscopic image for no-reference quality assessment with convolutional neural network. *Pattern Recognition*, 59(C), 2016, 176–187.
- [10] Y Lecun, Y Bengio, G Hinton. Deep learning. *Nature*, 521, 2015, 436–444.
- [11] J Schmidhuber. Deep learning in neural networks: An overview. *Neural Networks*, 61, 2015, 85–117.
- [12] J Yang, B Jiang, B Li, K Tian, Z Lv. A fast image retrieval method designed for network big data. *IEEE Transactions on Industrial Informatics*, 13(5), 2017, 2350–2359.
- [13] ZH Ling, SY Kang, H Zen, A Senior, M Schuster, XJ Qian, HM Meng, L Deng. Deep learning for acoustic modeling in parametric speech generation: A systematic review of existing techniques and future trends. *IEEE Signal Processing Magazine*, 32(3), 2015, 35–52.
- [14] D Holden, J Saito, T Komura. A deep learning framework for character motion synthesis and editing. *Acm Transactions on Graphics*, 35(4), 2016, 1–11.
- [15] Z Dong, Y Wu, M Pei, Y Jia. Vehicle type classification using a semisupervised convolutional neural network. *IEEE Transactions on Intelligent Transportation Systems*, 16(4), 2015, 2247–2256.
- [16] T. He, W. Huang, Y. Qiao, and J. Yao. Text-attentional convolutional neural network for scene text detection. *IEEE Transactions on Image Processing*, 25(6):2529–2541, 2016.
- [17] J. Wu and R. Jafari. Seamless vision-assisted placement calibration for wearable inertial sensors. *Acm Transactions on Embedded Computing Systems*, 16(3):1–22, 2017.
- [18] A Brutti, A Cavallaro. Online cross-modal adaptation for audio-visual person identification with wearable cameras. *IEEE Transactions on Human-Machine Systems*, 47(1), 2017, 40–51.
- [19] M Bolanos, M Dimiccoli, P Radeva. Toward storytelling from visual lifelogging: An overview. *IEEE Transactions on Human-Machine Systems*, 47(1), 2016, 77–90.

- [20] H. Lin, W. Xu, N. Guan, D. Ji, Y. Wei, and W. Yi. Noninvasive and continuous blood pressure monitoring using wearable body sensor networks. *IEEE Intelligent Systems*, 30(6):38–48, 2015.
- [21] E Nemati, MJ Deen, T Mondal. A wireless wearable ecg sensor for long-term applications. *IEEE Communications Magazine*, 50(1), 2012, 36–43.
- [22] R Fensli, PE Pedersen, T Gundersen, O Hejlesen. Sensor acceptance model - measuring patient acceptance of wearable sensors. *Methods of Information in Medicine*, 47(1), 2008, 89–95.
- [23] Y Wong, S Chen, S Mau, C Sanderson. Patch-based probabilistic image quality assessment for face selection and improved video-based face recognition. In *Computer Vision and Pattern Recognition Workshops*, 2011, 74–81.
- [24] D Gur, DA Rubin, BH Kart, AM Peterson, CR Fuhrman, HE Rockette, JL King. Forced choice and ordinal discrete rating assessment of image quality: A comparison. *Journal of Digital Imaging*, 10(3), 1997, 103–107.
- [25] S Wei, S Wang, C Zhou, K. Liu, X Fan. Binocular vision measurement using dammann grating. *Applied Optics*, 54(11), 2015, 3246–3251.